

## Simulation of Pressure Variation in Hydraulic circuit with & without Hydraulic Accumulator in MATLAB-Simhydraulics

Cherian Johny<sup>1</sup>, Dr.K.RSivadas<sup>2</sup>

<sup>1</sup>PG Student, Department. of Mechanical Engineering, SNGCE, Mahatma Gandhi University,India

<sup>2</sup>Professor, Department. of Mechanical Engineering, SNGCE, Mahatma Gandhi University,India

---

**Abstract:** The paper represents the modeling and simulation of a hydraulic circuit with and without accumulator in order to find variation of pressure in hydraulic system at the time of improper operation or malfunctioning. The cause of malfunction is due to fluid leakage, overheating, pressure drop, valve damage etc. The variation of pressure is monitored according to the spool movement inside the directional control valve. The hydraulic circuit is modeled in MATLAB-Simhydraulic using following details like working fluid, working Temperature, Technical details of reservoir, pump, directional control valve, Pressure relief valve, Hydraulic cylinder details, Block used to convert input signal to physical output signals and Physical Signal to a unit less Simulink output signal, sensors like pressure sensors, Flow sensors are used to monitor the pressure variation, accumulator & system flow rate and volume of fluid in accumulator. The variation in the presence of accumulator shows the importance of accumulator in a hydraulic system. Accumulator act as Emergency Operate, Damp Mechanical shock, absorb pressure oscillation, compensate leakage losses, stabilize pressure and compensate the effect of pressure drop in the system.

**Keywords** -Hydraulic circuit, Pressure variation, Simhydraulic, Simulation, Accumulator

---

### I. Introduction

Power transmission can be performed by the means electrical, mechanical and fluid power. Fluid power is generated by the means of liquid and gases. The liquid medium is used in hydraulic system because of advantages like generate under high pressure, provide huge force and torque. In Ancient days water is used for generating power by means of water wheels. Later viscous hydraulic fluid like synthetic oils is used because of very low pressure availability from water. The name Hydraulic in fact comes from the Greek word hydra meaning “water” and aulos meaning “pipe”. Most commonly used hydraulic fluid is petroleum oil because of good lubricating property and transmits power readily. The quality of hydraulic fluids depends on factors like good lubricant, ideal viscosity, fire resistance etc. While the physical property depends upon viscosity, density, pressure, compressibility.

The basic principal behind fluid power transmission is Pascal’s law & Bernoulli’s law. The fluid system is used in various applications like steering unit in automobile application, tractors and farm equipment, landing wheels of airplane & helicopters, used in missile launching systems, navigation controls, hydraulic press, CNC machines etc. The hydraulic system also shows several malfunctioning during operation and this will affect the performance of the system. Most of the problems are Pressure Fluctuation, leakage, overheating etc. The main aim of this work is to simulate a hydraulic circuit with accumulator and its result shows the advantage of using it.

### II. Aim and Objective

The aim & objective of this work is to Simulate the of pressure variation in Hydraulic circuit with & without hydraulic accumulator. Study also includes type of hydraulic components using and the function of each component. In order to simulate the variation of pressure the hydraulic circuit is modeled in MATLAB-Simhydraulic.

### III. Problem Statement

The periodical pulsation of hydraulic fluid during operation stresses each hydraulic component and reduces the life of these components. This causes the malfunctioningof hydraulic units in the form of Fluid leakage, Excessive vibration at power pack, overheating fluid etc. and affect the overall performance of the system. If the malfunction found inhydraulicmachinery the whole hydraulic system is need to analyses to find the cause of the problem. Most of these problems can be reduced by the use of Hydraulic Accumulator. The importance of accumulator in a hydraulic circuit is demonstrated using MATLAB.

#### **IV. Design Methodology**

In order to identify the importance of an accumulator in hydraulic circuit is simulated in virtual medium using simulation software MATLAB-simhydraulics. Simulink is a Software package used for simulating and analyzing dynamic behavior in a mechanical system, it works as the part of MATLAB. Simhydraulics is a part of Simulink library. It contains graphical symbols or components corresponding to the hydraulic system. With the help of Simhydraulic we can model the real world hydraulic application in a virtual workspace of MATLAB. For performing this simulation a hydraulic circuit is modeled used to move a load from one position to another. The movement of the cylinder is arrested correspondingly variation in pressure is monitored in the absence and presence of accumulator. The input signal to the system is given in the form of spool movement inside the directional control valve.

An hydraulic circuit consist of directional control valves, pressure control valve, hydraulic actuator, reservoir, hydraulic fluid, pump-sensors for monitoring the variation in pressure, flow rate, fluid level etc. The directional control valves are used to control the direction of flow in hydraulic circuit. According to the construction of internal moving parts DCV can be classified as sliding and rotary spool type. It is again classified as one way, two ways, three ways and four way valves depending upon number of port connection. In this simulation sliding spool type four way 3 position DCV is used to control the direction of flow. The pressure control valve are used in hydraulic circuits to maintain the desired pressure level in various parts of the hydraulic circuit, pressure relief valve as well as pressure reducing valve are used in this work. Flow control valve is used to control the flow through the circuit.

#### **V. Modeling in Simhydraulics**

The main purpose of this simulation is to justify the importance of using an accumulator to hydraulic circuit thus it will improve the performance of the system by reducing the sudden pressure variation. The circuit is modeled [8] by selecting corresponding blocks from Simhydraulics tool pallet of Simulink. The working fluid used to perform this simulation is ISO VG 32 having following Fluid property Density =  $857.2\text{kg/m}^3$ , Viscosity = 31.816 cst and bulk modulus =  $1.44756\text{e}09$  Pa. The fluid temperature is about  $40^\circ\text{C}$ . Several blocks are used to convert unit less input signal to physical signal and vice versa. Scope block is used to view the output required. Hydraulic pressure as well as Flow rate sensor is used to monitor the variation of pressure and system flow rate. The reservoir is a closed type and the pressurization level is about 0 Pa and fluid volume is about 100 L. The return line diameter to the reservoir is 24 mm.

A variable displacement pump is used to pressurize the fluid pressure with following technical details maximum displacement of  $1.35\text{in}^3/\text{rev}$ , Nominal pressure of 16MPa, nominal angular velocity of  $157\text{rad/sec}$  and nominal kinematic viscosity of 32 cSt at  $40^\circ\text{C}$ . Two type of pressure controlling valves are used one is pressure reducing valve which is used to maintain reduced pressure in specified locations in hydraulic system and the technical details of the valve are valve setting pressure of 1.47MPa, maximum passage area of  $1\text{e}^{-04}\text{m}^2$  and the another is pressure relief valve which is normally closed valve whose function is to limit pressure to a specified maximum valve by diverting the pump flow to the tank and the technical details of maximum passage area of  $1\text{e}^{-04}\text{m}^2$  and valve pressure setting is of 5.88 MPa.

A pilot operated check valve is used. Pilot lines are hydraulic lines that are used for control purposes. They typically send system pressure to component, so that the component can react to pressure changes. The free flow in the normal direction is achieved in a usual manner. But the reverse flow is blocked as the fluid pressure pushes the poppet into the closed position. In order to permit the fluid flow in the reverse direction the pilot pressure is applied through the pilot pressure port. The pilot pressure pushes the pilot piston and the poppet down. Thus the fluid flow in the reversed direction is also obtained. The purpose of the drain port in the circuit is to prevent oil from creating a pressure building in the bottom of the pilot piston. The maximum passage area is of  $1\text{e}^{-04}\text{m}^2$ , maximum opening pressure is of 1.47 MPa and cracking pressure of 0.7 MPa. The fluid discharged by pump is directed to the hydraulic actuator to perform useful work. These actuator converts pressurized fluid into mechanical energy. For this simulation linear motion- hydraulic cylinders are used which convert fluid power into linear mechanical force and motion and it usually consist of movable element, a piston and a piston rod. Double acting cylinder is used for the simulation which is capable to deliver forces in both directions piston stroke is of 35 mm, cylinder orientation- act in positive direction, having specific heat ratio as 1.4. The hydraulic circuit is simulated in the presence and absence of hydraulic accumulator. Gas accumulator is used having capacity of 1L, preloaded pressure of 0.1 Mpa and having specific heat ratio as 1.4. Signal builder is

used in order to give input signal to the system. The input signal which given to the system is by spool movement in DCV.

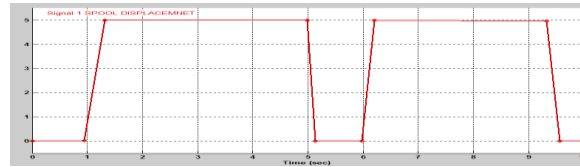
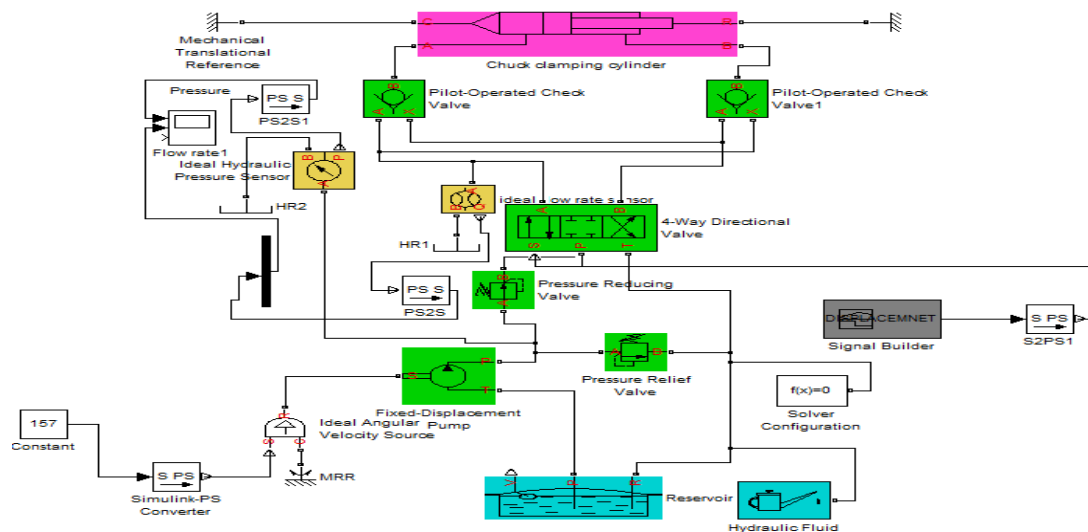

**Figure 5.1** Input signal given to DCV

The spool movement having displacement of 5mm is given as input to the hydraulic circuit. The simulation time is 10 sec which is shown in Fig.5.1 Hydraulic flow rate sensors are used to measure the variation of system as well as accumulator flow rate. This will help view how a sudden pressure drop in a system will affect the smooth functioning of the system. Hydraulic pressure sensors are used to monitor the pressure variation in the system. These variations are monitored using scope block which are connected to these sensors in order to monitor the variation in the system. Simulink PS converts the unit less input signal to a Physical signal. PS Simulink converts the input physical signal to unit less Simulink output signal.

## VI. Result and Discussion

The whole hydraulic circuit is modeled in MATLAB-Simhydraulic workspace. The hydraulic circuit without accumulator shown in Fig.6.1 is initially simulated in order to monitor the pressure variation and system flow rate.



**Figure.6.1** Hydraulic circuit without accumulator

Fig.6.2 shows the simulation result. From the result pressure variation in Pa, flow rate in m<sup>3</sup>/sec and fluid volume in m<sup>3</sup>. The result shows that whenever the pressure drop occur at that time system flow rate get raised this will affect the proper functioning of other hydraulic modules. Thus it will affect the overall functioning of the system.

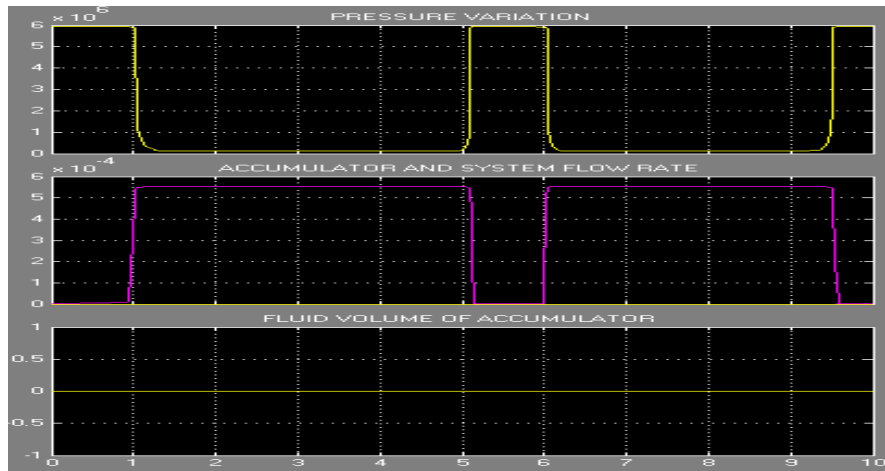

**Figure.6.2** Simulation result without accumulator

The result shows the sudden variation in pressure without the accumulator unit. Again the hydraulic circuit is modeled with accumulator unit then corresponding result is monitored. During this simulation an ideal hydraulic flow rate sensor is used to monitor the flow rate in the accumulator and gas charged accumulator are used. The fluid volume in the hydraulic circuit is also monitored.

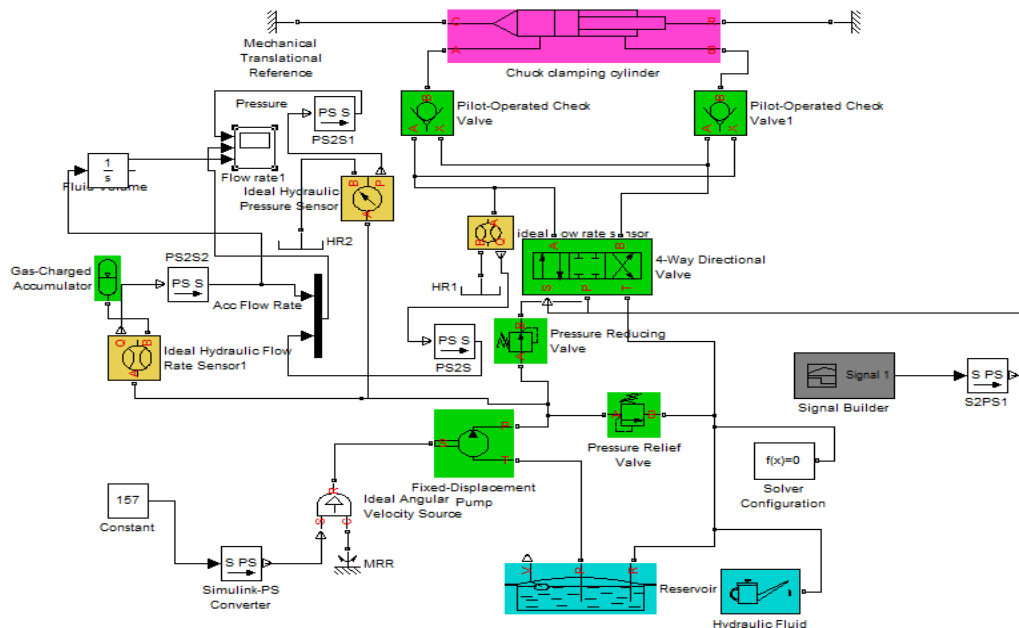

**Figure.6.3** Hydraulic circuit with accumulator

The simulation result in the presence of accumulator shows how the pressure variation in the hydraulic system can be controlled whenever the system flow rate varies it is compensated by the accumulator.

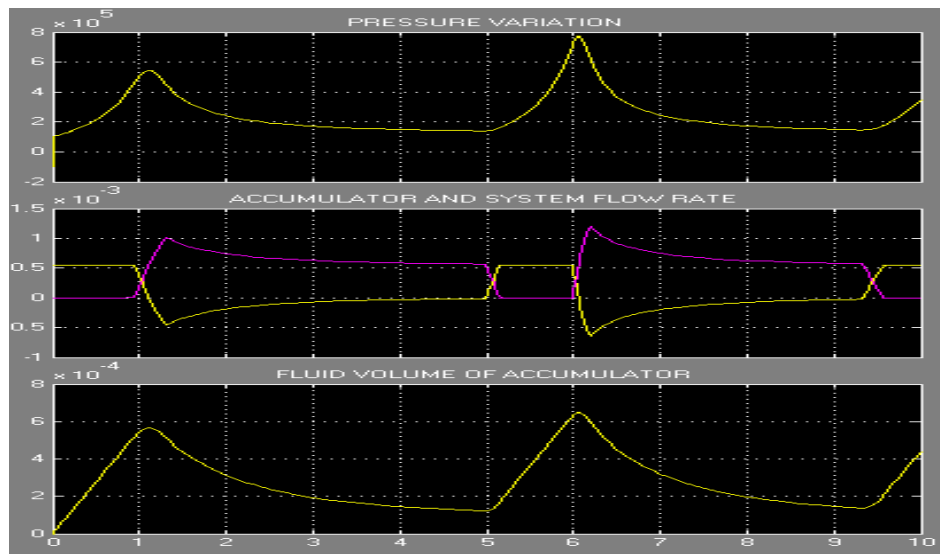

**Figure.6.4** Simulation Result with accumulator

Result shown in Fig 6.4 shows whenever the system pressure get drop it is compensated by the presence of Accumulator. At this time we can monitor the flow rate in system and how this is controlled by accumulator flow rate. Result also shows the fluid volume in Accumulator. Thus the result shows that accumulator act as Emergency Operate whenever required, Damp Mechanical shock due to sudden pressure variations, absorb pressure oscillation, compensate leakage losses, stabilize pressure and compensate the effect of pressure drop in the system.

## VII. Conclusion

The main objective of this study is to compare advantage of using an accumulator unit in a hydraulic circuit by simulation using MATLAB-Simhydraulics. The circuit without accumulator shows that whenever the system pressure drops, the system flow rate to increases to that location. This will affect the smooth operation of Hydraulic units in other locations. At the same time the hydraulic system with accumulator reduces the pressure drop in the system also whenever the amplitude of pressure get reduced it is compensated using accumulator. Thus accumulator unit act as an emergency operator whenever the system get fail during the time of operation. Accumulator act as Emergency Operate at the required situations, Damp Mechanical shock occur during sudden variations in pressure, absorb pressure oscillation, compensate leakage losses occur from actuators, stabilize pressure and compensate the effect of pressure drop in the system.

## References

- [1]. Adam Burecek, Lumir Hruzik, Martin vasina, *Simulation of Accumulator Influence on hydraulic Shock in long Pipe*, Journal of Manufacturing and Industrial Engineering 2015 ISSN 1339-2972.
- [2]. M.Kbarnwal, N.Kumar, Ajit Kumar and J.das, *Effect of hydraulic Accumulator on the system paramerter of an open loop Transmission system*, 5th international & All India Manufacturing Technology, Design 7 research conference 2014.
- [3]. R.Wang et al, *Water hammer Assessment techniques for water distribution systems*, 12<sup>th</sup> International Conference on Computing and Control for the water Industry,CCW12013.
- [4]. Gregov.G & Siminitai.D, *Computer simulation of laboratory hydraulic system with MATLAB-Simulink*, Advanced Engineering 4(2010), ISSN 1846-5900.
- [5]. *MATLAB and its Application In Engineering* by Raj Kumal Banasal.
- [6]. *Fluid power Theory and application* by James A sullivan.
- [7]. *Hand book of fluid dynamics and fluid machineris* by joseph A schetz and allen. Efuhs.
- [8]. Matlab 2011a Tutorial Related to SimuHydraulics.